

1SEB30 - Overcenter Valve

Fully balanced, pilot assisted relief with check
30 L/min (8 USgpm) • 270 bar (4000 psi)

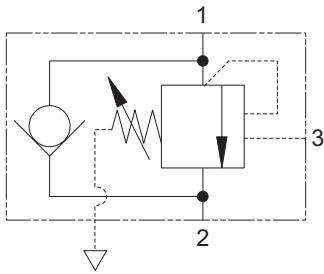

Sectional View

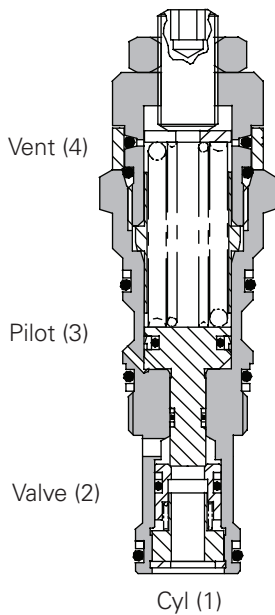

Operation

The check section allows free flow into the actuator then holds and locks the load against movement. The pilot assisted relief valve section will give controlled movement when pilot pressure is applied. The relief section is normally set to open at a pressure at least 1.3 times the maximum load induced pressure but the pressure required to open the

valve and allow movement depends on the pilot ratio of the valve. For optimization of load control and energy usage, a choice of pilot ratios is available.

The pressure required to open the valve and start actuator movement can be calculated as follows:

$$\text{Pilot Pressure} = \frac{(\text{Relief Setting}) - (\text{Load Pressure})}{\text{Pilot Ratio}}$$

Features

Cartridge is economical and fits simple cavity. Allows quick, easy field service - reduces down time. Interchangeable with pilot check valve of a similar size.

Pilot Ratio

5:1

Performance Data

Ratings and Specifications

Figures based on: Oil Temp = 40°C Viscosity = 32 cSt (150 SUS)

Rated flow	30 L/min (8 USgpm)
Max relief setting	350 bar (5000 psi)
Max load induced pressure	270 bar (4000 psi)
Cartridge material	Working parts hardened and ground steel. External steel surfaces zinc plated.
Mounting position	Unrestricted
Cavity number	A20090-T11A
Torque cartridge into cavity	45 Nm (33 lbs ft)
Weight	0.14 kg (0.30 lbs)
Seal kit number	SK1079 (Nitrile) SK1079V (Viton®)
Recommended filtration level	B55540/4 Class 18/13 (25 micron nominal)
Operating temperature	-30° to +90°C (-22° to +194°F)
Leakage	0.3 milliliters/min nominal (5 dpm)
Nominal viscosity range	5 to 500 cSt

Description

Overcenter valves give static and dynamic control of loads by supplying a counterbalance pressure to the actuator. They prevent runaway in the event of hose burst and hold the load with minimal leakage.

The pressure balanced valve is unaffected by back pressure, allowing service line reliefs to operate and for the valve to be used in regenerative or proportional valve systems.

The overcenter valve should be mounted either into, onto or as close to the actuator as possible to give maximum protection.

Single overcenter valves control unidirectional loads such as in aerial platforms, cranes or winches and dual overcenters are suited to bi-directional motion such as wheel motor applications or cylinders going over center.

Pressure Drop

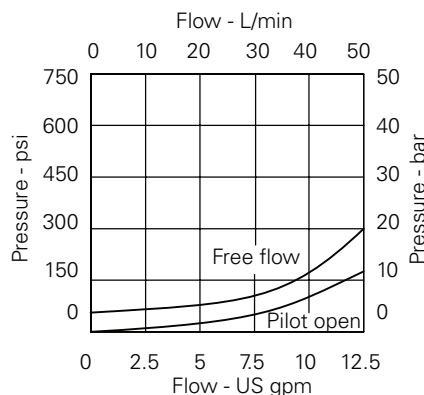

Where measurements are critical request certified drawings. We reserve the right to change specifications without notice.

1SEB30 - Overcenter Valve

Fully balanced, pilot assisted relief with check
30 L/min (8 USgpm) • 270 bar (4000 psi)

Model Code

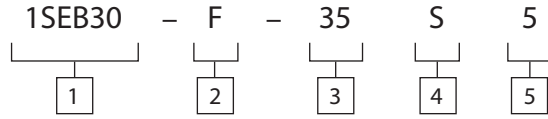

1 Function 1SEB30	2 Adjustment Means F - Screw Adjustment N - Fixed - State pressure setting required For fixed versions add setting in 10 bar increments to end of part number. Subject to a ±10% tolerance.	3 Pressure Range @ 4.8 L/min Note: Code based on pressure in bar. 35 - 75-350 bar Std setting 210 bar Std setting made at 4.8 L/min	4 Seals S - Nitrile (For use with most industrial hydraulic oils) SV - Viton (For high temperature and most special fluid applications)
			5 Pilot Ratio 5 - 5:1

Dimensions

mm (inch)

Cartridge Only
Basic Code
1SEB30

Cavity
Model A20090-T11A
Form Drill TD-11A
Form Reamer TR-11A

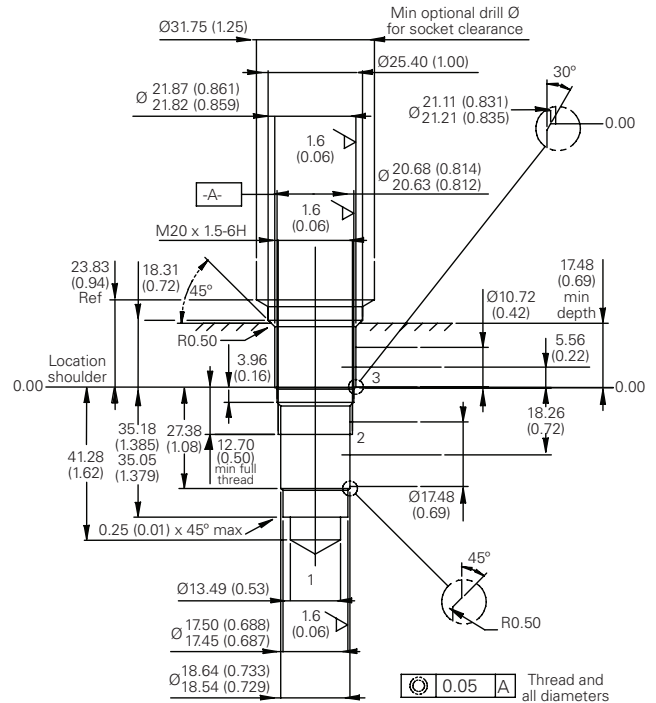
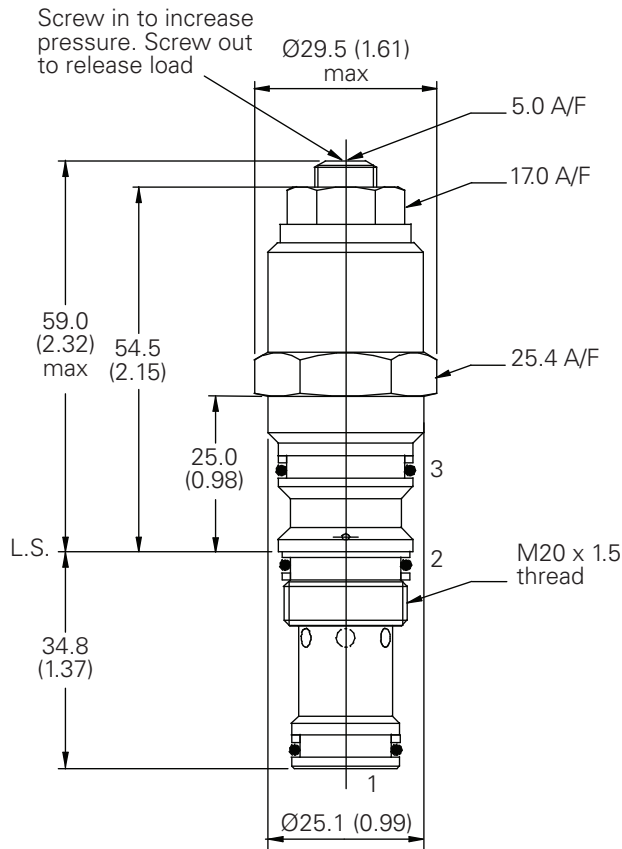

Note: Tightening torque of "F" adjuster locknut - 20 to 25 Nm